

BL-22/23/24 Laser Photoelectric Sensor

DESCRIPTION

The BL-22/23/24 series photo-electric sensors use a modulated visible red, 670 nanometer wavelength, Class II laser diode emitter that visually aids in alignment. The unit has an adjustable intensity control. The collimated laser beam is small in diameter [approx. 2mm @ 4 in.] and is capable of discerning small objects, small features on an object, or precision detection of edges.

There are both a PNP(sourcing) and an NPN(sinking) output operating simultaneously. Each is rated for a 200ma load, and over current and transient protected. The mode of operation of the outputs is determined by the "light-on/dark-on" switch on the top of the case. A RED indicator LED on the top of the case turns "on" when the outputs are "on".

The power source may be any voltage from +10VDC to +30VDC. A GREEN "power on" indicator LED is located on the top of the case which also serves as a laser emission indicator.

Power and output signals are accessed through a four (4) pin PICO (M8x1) style connector at the bottom of the unit.

MOUNTING

Select a mounting location on a solid flat surface free of vibration. The greater the sensing distance the more critical this is. Locate the center of the mounting holes with a center punch. (Hole spacing is 1.06in. or 27mm). Drill the two mounting holes and any wire or cable access holes as required. Mount the unit in the selected location and lightly tighten the mounting screws. Route the quick disconnect cable so that it is located in a position where it cannot be damaged or subjected to excessive electrical noise. Connect the cable to the sensor.

ALIGNMENT

Diffuse sensing mode (Background Suppression)

1. Select a mounting position giving a clear view of the object to be sensed maintaining a minimum of 1/2" between the object and the background. This is a background suppression unit at 4.5". As the intensity potentiometer is turned counter-clockwise and intensity

decreases, so will the sensing range as well as the background suppression (example: 3 inch to detect object 3.5 inches for background suppression). Care should be exercised to avoid unwanted reflections into the eyes of personnel or the receivers of other sensors.

2. Open the clear protective control cover and set the output mode switch to "light-on" (in some cases the user may require a logic inversion in which case "dark-on" should be substituted for "light-on").

3. Apply power and turn the intensity control clockwise until the laser spot is visible on the object to be detected. Move the body of the sensor so that the laser spot is on the most desired feature to be detected. Tighten the mounting screws. Increase the intensity until the red output indicator turns "on". Remove the object and continue to increase the intensity (clockwise) until the background reflectance causes the output to turn "on". Decrease (counter-clockwise) the intensity control halfway between where the output turned on with the object in view and the previous position where the output turned on through background reflectance. If the output did not turn on when the intensity control was turned to maximum with no object present, decrease the intensity to halfway between maximum and where the output turned on with the object present.

4. If there will be variations in surface reflectivity and surface angle with respect to the laser beam, experiment with the worst case examples of objects and the angle of their surfaces to be detected and try to obtain the best compromise in intensity setting. Smooth, shiny surfaces may not be detected if they are even at a slight angle to perpendicular to the laser beam because they will reflect the highly directional laser light away from the sensor. If the shiny surface is irregular and uneven compared to the laser spot size, it may cause the sensor to turn on and off more than once for the same object. An external adjustable off-delay relay or time-out programmed into a programmable logic controller (PLC) may compensate for this problem under the right conditions.

Sensing Areas

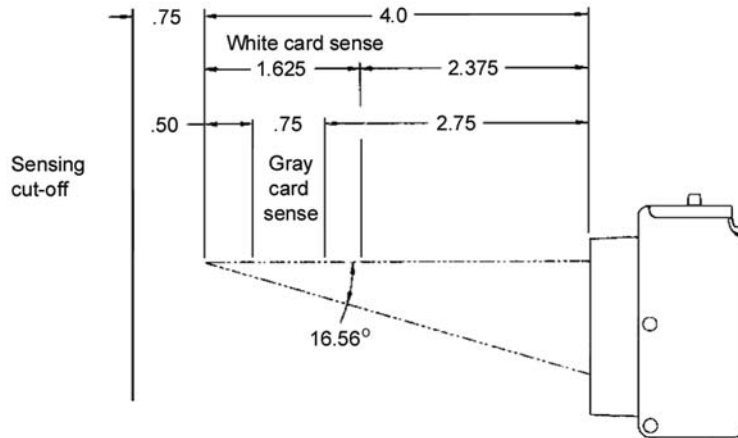

Operating Diagram

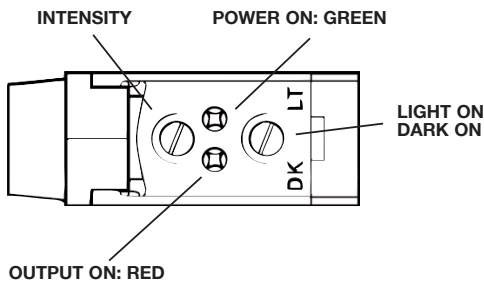

Housing Dimensions

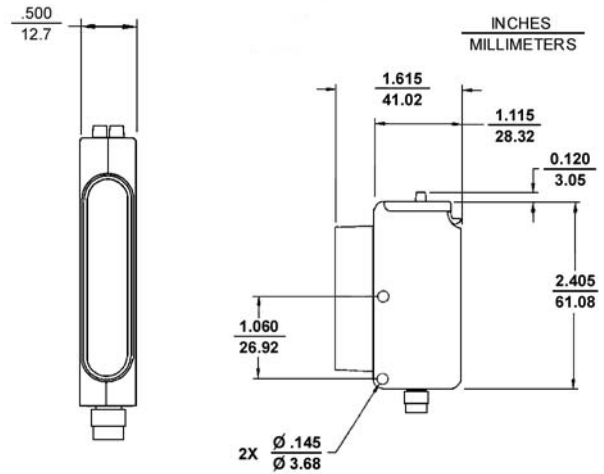

Wiring Diagram

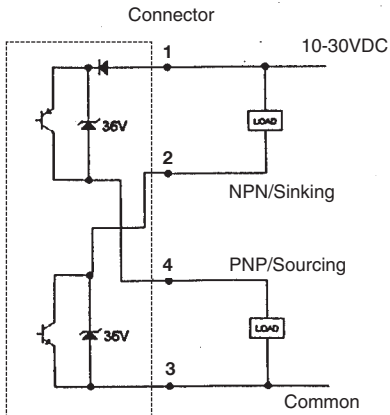

Cable Wiring Diagram

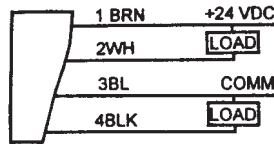

P/N7700-025-01-00

Housing Connector

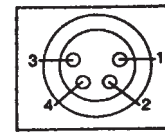

(Pico)

- 1. Brown 10-30VDC
- 2. White NPN
- 3. Blue Comm
- 4. Black PNP

CAUTION

LASER RADIATION - DO NOT STARE INTO BEAM

Visible Laser Diode
Wavelength 670 nm
1 mW max Output
Class II laser product

This product complies with 21 CFR Sub Chapter J

BL-22/23/24 Laser Photoelectric Sensor

Specifications

Supply Voltage:	10 to 30 VDC
Supply Current:	30 mA maximum
Output Configuration:	One current sourcing (PNP) and one current sinking (NPN) open collector transistor, both operating simultaneously
Output Mode:	Set by "Light-ON"/ "Dark-ON" switch
Output Rating:	200mA max. each output. Output saturation less than 0.2 volts @ 10mA, less than 0.6 volts @ 200 mA
Output Protection:	Protected against current overload, inductive transients
Response time:	Less than 2 ms, > 500 Hz
Sensing Range	
Diffuse:	<p>4" Version: 2.375 in. min. to 4.0 in. max. typical to 90% white Kodak card, 2.75 in. min. to 3.5 in. max. typical to 18% white Kodak card.</p> <p>6" Version: 3.41 in. min. to 6.0 in. max. typical to 90% white Kodak card, 3.44 in. min. to 4.58 in. max. typical to 18% white Kodak card.</p> <p>8" Version: 4.22 in. min. to 8.0 in. max. typical to 90% white Kodak card, 4.60 in. min. to 5.4 in. max. typical to 18% white Kodak card.</p>
Indicators:	Power on - Green, Output on - Red
Adjustments:	Single turn intensity control, two position Light operate or Dark operate switch
Emitted Beam:	670 nm visible red laser diode
Average Light:	Less than 150 µw at max. intensity setting (2.4 mW peak @ 6.2% duty cycle)
Average Output Power:	150 µw
Housing:	NEMA 6, potted ABS, acrylic window, polycarbonate cover
Connector	
Pico:	4 pin M8x1. Pin 1- power, Pin 2 - NPN output, Pin 3 - common, Pin 4 - PNP output
Operating Temp.:	0° to 40° C (32° to 104° F)
Agency Approval:	CE Approved following the provision of EMC directive 89/336/EEC.

Caution - use of controls or adjustments or performance of procedures other than those specified herein may result in hazardous radiation exposure.

Reflector

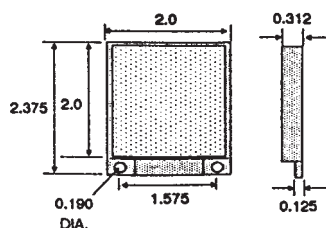

P/N 0000-181-52-00

Mounting Bracket P/N 7700-114-01-00

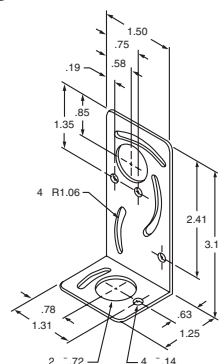

All lengths are in inches

CONVERSION FACTORS

To Convert	Multiply by	To Convert
mm	0.03937	in.
M	3.281	ft.
g	.0353	oz.
Kg cm	.07	ft. lb.

BL-22/23/24 Laser Photoelectric Sensor**Model BL-22/23/24 Ordering Code**

Sensor Type	Model Number	Diffuse Sensing Range	Connector Type
Convergent Beam	BL-22D-Q8	60 ~ 100 mm (2.4 ~ 4.0")	M8 - QD
	BL-23D-Q8	86 ~ 150 mm (3.4 ~ 6.0")	M8 - QD
	BL-24D-Q8	107 ~ 203 mm (4.2 ~ 8.0")	M8 - QD

All information is subject to change without prior notice.

<http://www.ramcosensors.com>

Ramco Innovations

1207 Maple St. West Des Moines, IA 50265 USA
Phone: 515-225-6933 FAX: 515-225-0063

1-800-280-6933